

## N83524 Series Multi-channel Dual-quadrant Battery Simulator

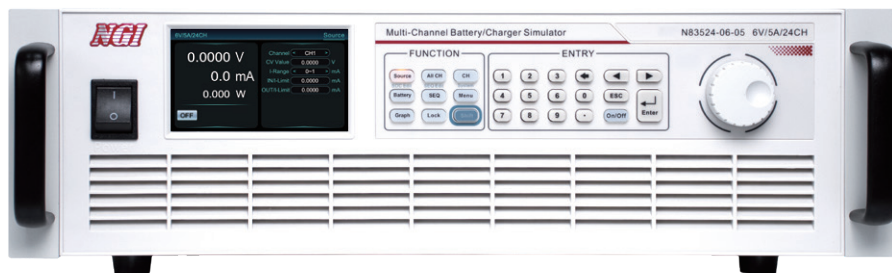

### Product Introduction

N83524 is a programmable battery simulator with low-power, multi-channel and high-accuracy. By adopting dual-quadrant design, the current can be charged and discharged, which can satisfy the needs of BMS test and consumer electronics ATE test. Its voltage accuracy is up to 0.6mV, supporting  $\mu$ A-level current measurement, standalone up to 24 channels. The channels are isolated from each other, which is convenient for series connection. N83524 supports both local operation and remote operation via LAN/RS232 /CAN interface. N83524 application software is easy to use, which can meet demands of battery simulators in multi-channel, multi-parameter, and complex test environments.

### Application Fields

- ▶ BMS/CMS test for new energy vehicle, UAV and energy storage
- ▶ Battery protection board test
- ▶ Portable consumer electronics R&D and production, such as mobiles, bluetooth earphones, smartwatch, etc.
- ▶ Electric tools manufacturing test, such as electric screw driver
- ▶ Power supply to low power products, such as DC-DC, wireless charging products
- ▶ Battery maintenance device test

### Main Features

- ▶ Voltage range: 0~6V
- ▶ Voltage accuracy up to 0.6mV
- ▶ High integration, standalone up to 24 channels, each channel isolated
- ▶  $\mu$ s-level dynamic response, simulating the characteristics of real battery
- ▶ Optional NB108 series products to achieve fault simulation and nA-level current measurement
- ▶ Supporting charge mode, battery simulation, SEQ test, SOC test
- ▶ 4.3 inch high-definition color LCD screen, local/remote control, standard application software
- ▶ LAN port, RS232 interface, CAN interface; dual LAN ports, convenient for cascade application
- ▶ Current range:  $\pm 1A/\pm 3A/\pm 5A$
- ▶  $\mu$ A-level current measurement
- ▶ Voltage ripple noise  $\leq 2mV_{rms}$

### Active/passive balancing test

By bidirectional current design, each channel supports up to 5A current input and output. Users can customize the battery charge and discharge model, which fully meets the requirements of BMS active/passive balancing test.

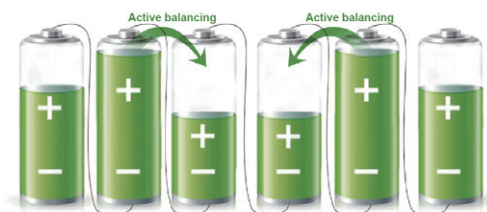

### Fast dynamic response

N83524 series has fast dynamic response capability. The response time of load varying from 10% to 90% and voltage recovering within 50mV of previous voltage is less than 100µs, which can ensure the rise and fall waveform of voltage is high-speed and without overshoot, and provide stable output voltage to the DUT.

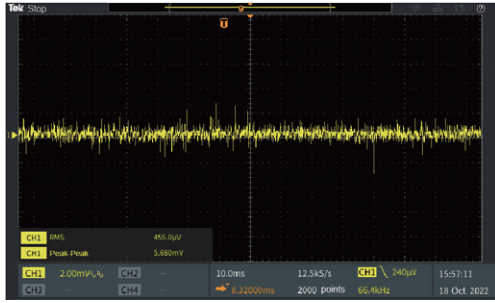

▲ Voltage Ripple Noise < 2mVrms



▲ Transient Recovery Time < 100µs

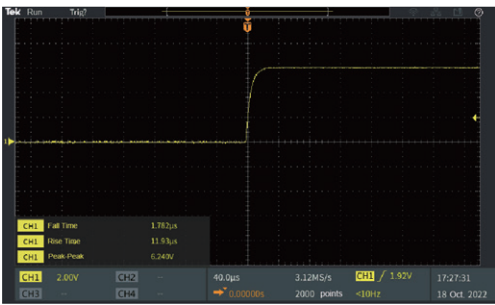

▲ Voltage Rise Time at Full Load < 40µs

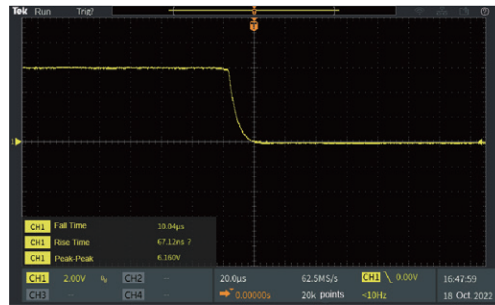

▲ Voltage Fall Time at No Load < 100µs

### Battery simulation suitable for BMS chips test of various specifications

N83524 series battery simulators have multiple functions and features, supporting Source, Charge, Battery Simulation, SOC Test, SEQ Test, Graph, etc. N83524 can achieve high-precision voltage and current measurements to quickly verify the response of various portable electronic products under different battery conditions.

One device can achieve multiple uses, streamline test equipment and optimize test procedures. N83524's internal circuit is optimized for different chips, which can be adapted to test BMS chips of various specifications.

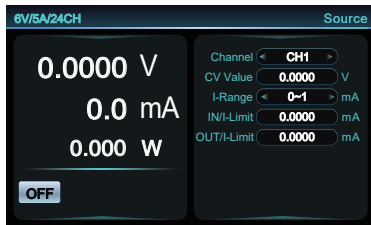

▲ Source

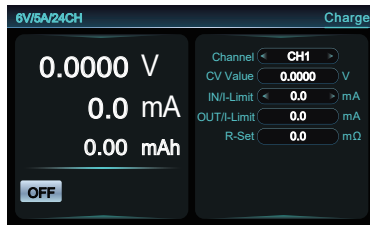

▲ Charge

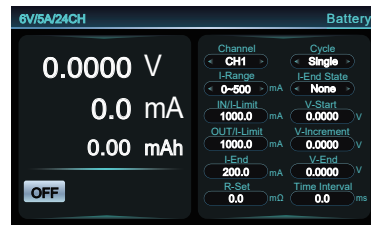

▲ Battery

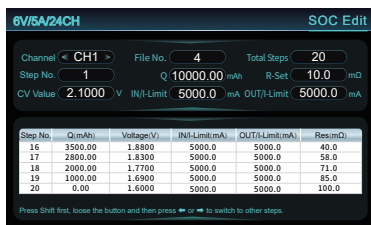

▲ SOC Edit

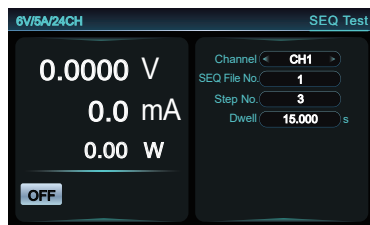

▲ SEQ Test

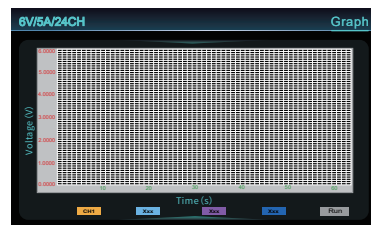

▲ Graph

### Optional fault simulation unit

N83524 integrates 24 independent output channels in a 19-inch 3U chassis. By optional NB108-2 fault simulation unit (as shown in the below figure), it can realize simulation of 24-channel positive&negative short circuit, positive&negative open circuit and reverse polarity. By NB108-2, it can improve the integration of test system, reduce complicated wiring, save space and reduce costs for users.



### Product Dimension

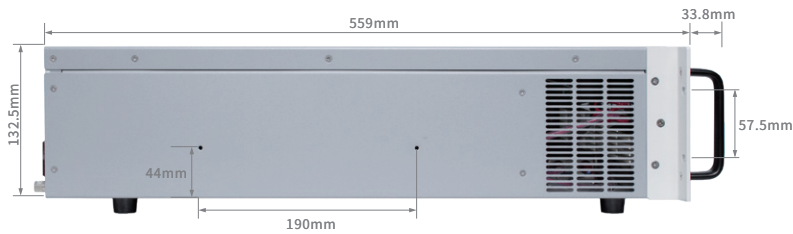
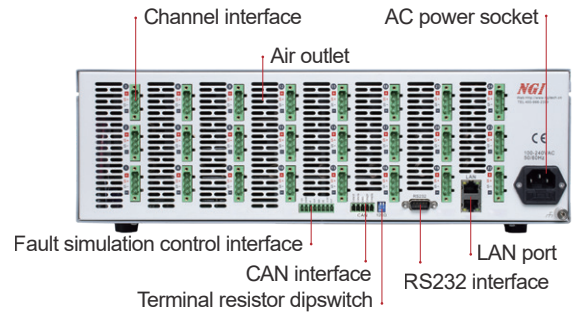
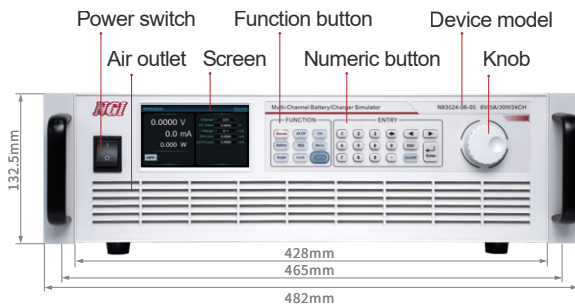

## Technical Data Sheet

Model	N83524-06-01		N83524-06-03		N83524-06-05	
Current	±1A/CH		±3A/CH		±5A/CH	
Voltage	6V/CH					
Power	6W/CH		18W/CH		30W/CH	
Channels	24CH					
CV Mode						
Range	0~6V					
Setting Resolution	0.1mV					
Setting Accuracy (23±5°C)	0.6mV					
Readback Resolution	0.1mV					
Readback Accuracy (23±5°C)	0.6mV					
Temperature Coefficient (0~40°C)	20ppm/°C					
Long-term Stability	80ppm/1000h					
Voltage Ripple Noise	≤2mVrms					
CC Mode						
Range	-1~1A	-1~1mA	-3~3A	-1~1mA	-5~5A	-1~1mA
Setting Resolution	0.1mA	0.1μA	0.1mA	0.1μA	0.1mA	0.1μA
Setting Accuracy (23±5°C)	1mA	1μA	3mA	1μA	5mA	1μA
Readback Resolution	0.1mA	0.1μA	0.1mA	0.1μA	0.1mA	0.1μA
Readback Accuracy (23±5°C)	1mA	1μA	3mA	1μA	5mA	1μA
Temperature Coefficient (0~40°C)	30ppm/°C					
Long-term Stability	100ppm/1000h					
Dynamic Characteristics						
Voltage Rise Time	<40μs ( no load ) (10%-90%F.S. Variation Time)					
Voltage Rise Time	<40μs ( pure resistive full load ) (10%-90%F.S. Variation Time)					
Voltage Fall Time	<100μs ( no load ) (90%-10%F.S. Variation Time)					
Voltage Fall Time	<100μs ( pure resistive full load ) (90%-10%F.S. Variation Time)					
Transient Voltage Drop <sup>1</sup>	350mV					
Transient Recovery Time <sup>2</sup>	<100μs					
Others						
Load Regulation	0.01%+0.2mV					
Isolation (Output to ground) <sup>3</sup>	1500VDC					
Isolation (Inter-channel)	500VDC					
Communication Response Time	≤10ms					
Interface	LAN/RS232/CAN					
AC Input	Single phase, 100~240V AC, current≤8A@220V,≤14A@110V, frequency 47Hz~63Hz					
Temperature	Operating temperature: 0°C~40°C, storage temperature: -20°C~60°C					
Operating Environment	Altitude <2000m, relative humidity: 5%~90%RH(non-condensing), atmospheric pressure: 80~110kPa					
Net Weight	Approx. 17kg; Approx. 20kg with NB108-2					
Dimension	3U,132.5mm(H)*482.0mm(W) with handle*559.0mm(D) 3U,132.5mm(H)*482.0mm(W) with handle*725.9mm(D) with NB108-2					

Note 1: Load varies from 10% to 90% by full voltage output.

Note 2: Load varies from 10% to 90% by full voltage output, with voltage recovering within 50mV of previous voltage.

Note 3: When multiple devices with multiple channels are connected in series, the total output voltage of each channel should be ≤1500V DC.

Note 4: For other specifications, please contact NGI.

Note 5: All specifications are subject to change without notice.